

JATCO CVT and DaimlerChrysler



by Sean Boyle

Part 2 Electronic and Computer Control Systems

In the last issue of *GEARS*, we began looking at the JATCO Continuously Variable Transmission (CVT) being offered with the 2007 Jeep Compass, Patriot, and Dodge Caliber. We examined its basic construction, and discussed powerflow through the unit.

In this issue, we're going to look into the electronics and control systems used to operate this new transmission, beginning with the valve body.

Valve Body

The JATCO CVT valve body consists of pressure sensors, variator pressure solenoids, torque converter clutch solenoids, and a unique stepper motor for controlling the pressure split between the primary and secondary variators.

The stepper motor works (1) in conjunction with the Ratio Control Valve and (2) as a mechanical link, which connects the ratio control valve and stepper motor to the primary variator (4).

The ratio control valve works in three different modes: feed, hold, and vent. These modes determine the ultimate position of the variators and control the resulting ratios (Figure 1).

When the TCM is satisfied with the ratio and the position of the variators, the ratio control valve (2) is in the *hold* position. Line pressure from the pump is fed into the secondary variator (5) to establish the necessary clamping force on the belt (Figure 2).

When the TCM wants a higher

ratio to reduce engine RPM, the stepper motor (1) moves out, which moves the ratio control valve (2) out. This allows line pressure to enter the primary variator (4). The additional pressure entering the primary variator causes the variator halves to squeeze together, causing the belt to ride toward the outer diameter (simulate large gear). Once the primary variator moves enough to satisfy the TCM, the ratio control valve moves back into the *hold* position.

The position of the ratio control valve depends on the position of the variator and the stepper motor. The TCM can alter the ratio by actuating the stepper motor, letting the variator change until it moves the ratio control valve back into the hold position. This is possible because these three components are linked together mechanically.

The fluid release in the secondary variator is controlled by the secondary pressure control solenoid and valve (3). As this solenoid is actuated, the pressure trapped in the secondary variator (5) can either exhaust, or line pressure can be directed to it to increase the clamping load. This is all controlled by the TCM.

During the ratio change from low to high, the secondary variator pressure exhausts to allow the ratio change. Once the change is complete, line pressure is once again directed into the secondary variator to provide clamping load (Figure 3).

When shifting from high to low ratio, the TCM moves the stepper motor in, which moves the ratio control valve

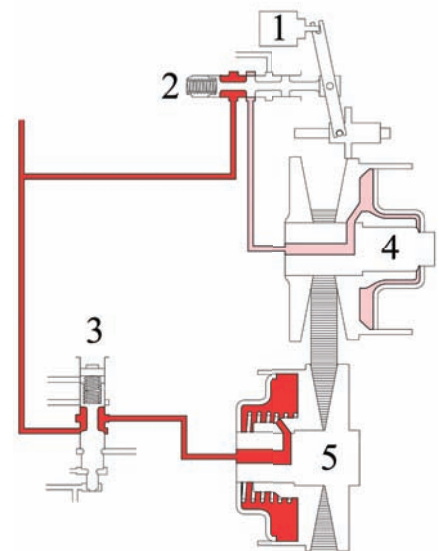

Figure 1: Ratio Hold Mode

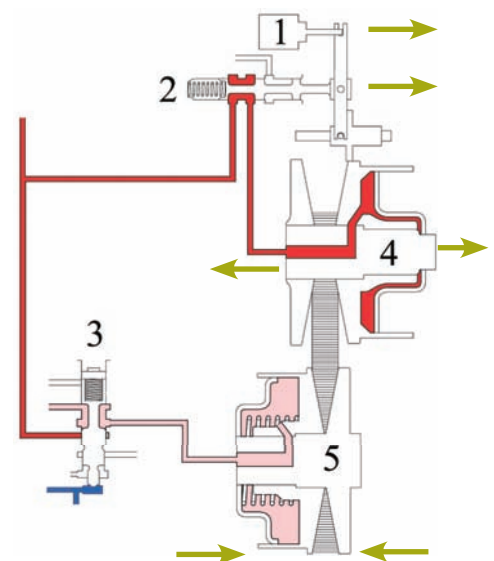
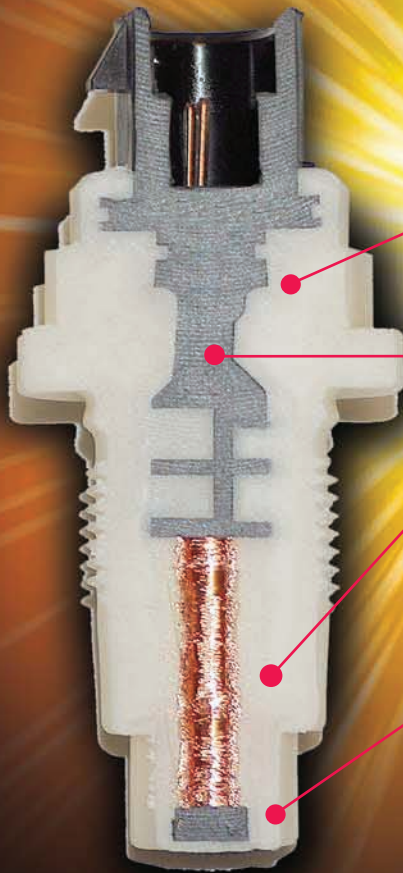

Figure 2: Low to High Ratio

I N T R O D U C I N G T H E
REVOLUTIONARY NEW



INPUT

Part No. RE92888

Windings & terminal connections impervious to contamination

Plastic fully encloses lead wire for support

Plastic fully surrounds coil

Extended Sure-Signal™ tip ensures stronger signal

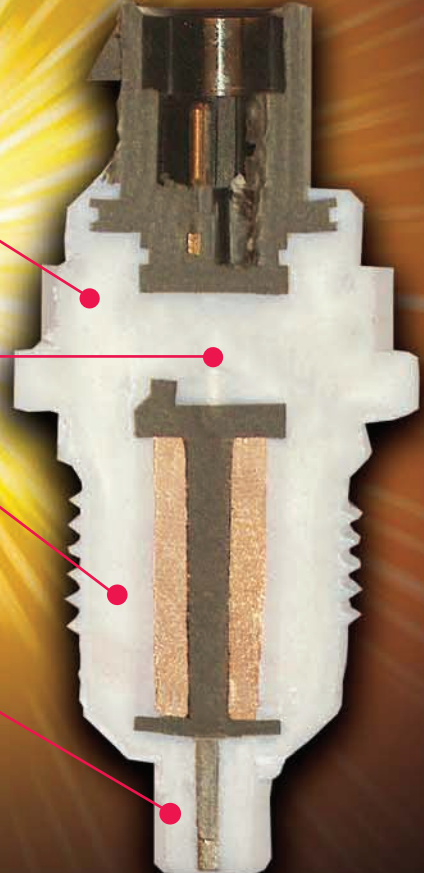

OUTPUT

Part No. RE92887

SPEED SENSORS

IN RESPONSE TO THE INDUSTRY NEED FOR A DEPENDABLE SOLUTION TO FAULTY SPEED SENSORS, RAYBESTOS POWERTRAIN HAS DEVELOPED INPUT AND OUTPUT SPEED SENSORS SUPERIOR TO OE. OUR PATENT PENDING DESIGN IS COMPLETELY IMPERVIOUS TO MOISTURE, AS ALL INTERNAL COMPONENTS ARE FULLY SUPPORTED AND PROTECTED FROM OUTSIDE CONTAMINANTS.

MORE INNOVATIVE SOLUTIONS FOR THE AFTERMARKET

Raybestos
POWERTRAIN

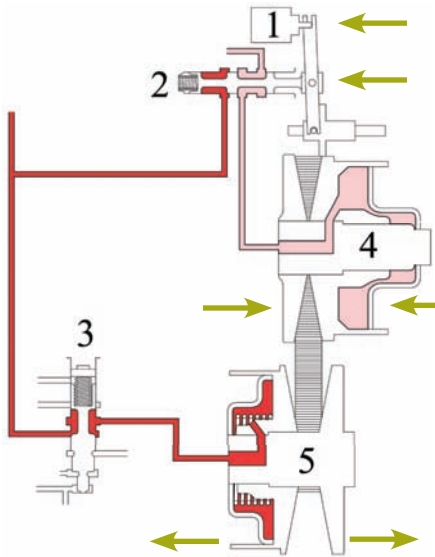

Figure 3: High to Low Ratio



Figure 4

into the *vent* position. The fluid in the primary variator exhausts, which allows the sheaves to spread and allows the belt to ride toward its inner diameter.

The secondary variator is still fed line pressure, which in turn causes it to squeeze the sheaves together, making the belt ride toward its outer diameter. The net result is a lower gear ratio. Once the ratio has changed enough to move the ratio control valve into the hold position, pressures are stabilized between the primary and secondary variators.

Obviously, this can happen at any speed and any engine RPM. The TCM uses electrical inputs, such as throttle position, manifold absolute pressure, fluid temperature, speed sensors (CKP, ISS, OSS), pressure sensors, range sensor, etc., to determine the proper ratio.

So far we've looked primarily at the ratio control valve and the secondary pressure control valve, but the

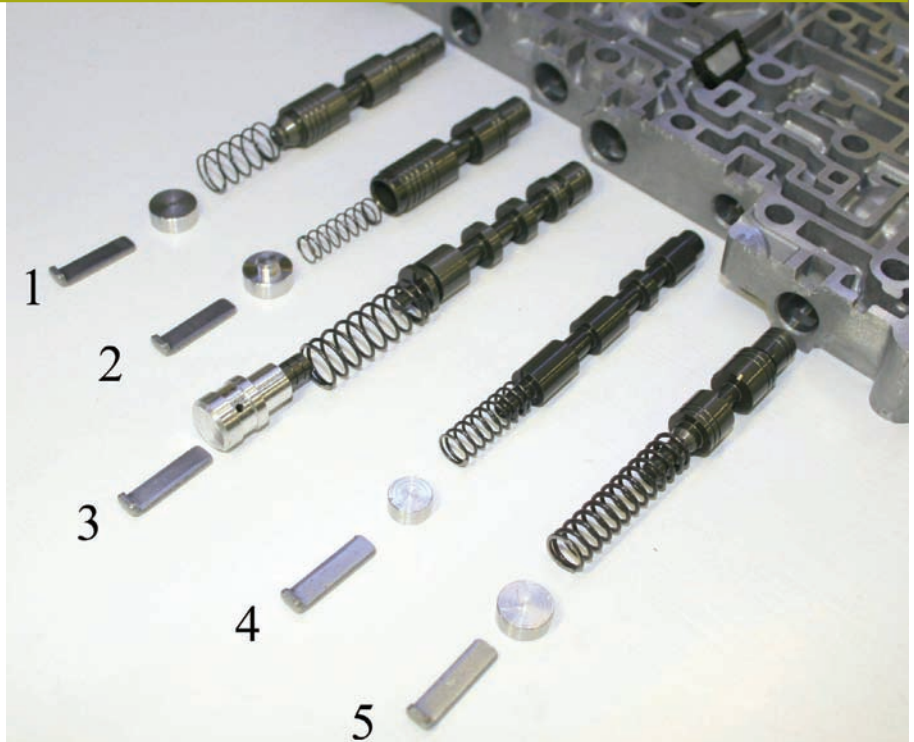

Figure 6

- 1 Secondary Pulley Control
- 2 Clutch Reducing Regulator Valve
- 3 Lockup Control
- 4 Select Switch Valve
- 5 Select Control Valve
- 6 Solenoid Regulator Valve

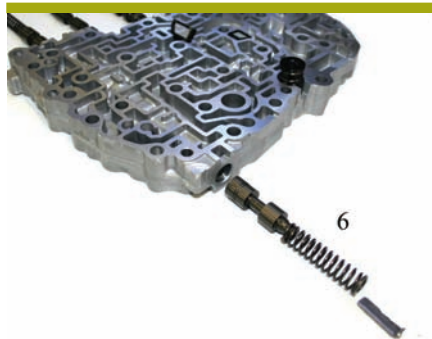

Figure 5

JATCO CVT has a few other very important valves.

Pressure regulator type valves: The oil pump (Figure 4) has the ability to generate over 1000 PSI, but not everything in the CVT needs this much pressure. Because 800+ PSI is more than most circuits need, line pressure is regulated down to three lower levels.

- 1) 218 PSI max for the clutches
- 2) 145 PSI max for the TCC
- 3) 60 PSI max for the lube and cooler circuits

The line pressure regulator valve (Figure 5) determines the overall highest pressure in the transmission. All

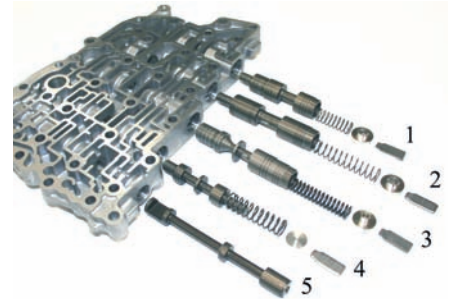

Figure 7

- 1 Secondary Pulley Regulator
- 2 Pressure Regulator 1
- 3 Pressure Regulator 2
- 4 TCC Regulator Valve
- 5 Manual Valve

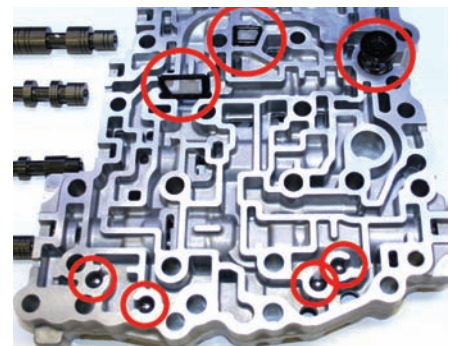

Figure 8

other pressures originate from line pressure, which can vary between 72 and 870 PSI, depending on operating conditions. The pressure is controlled

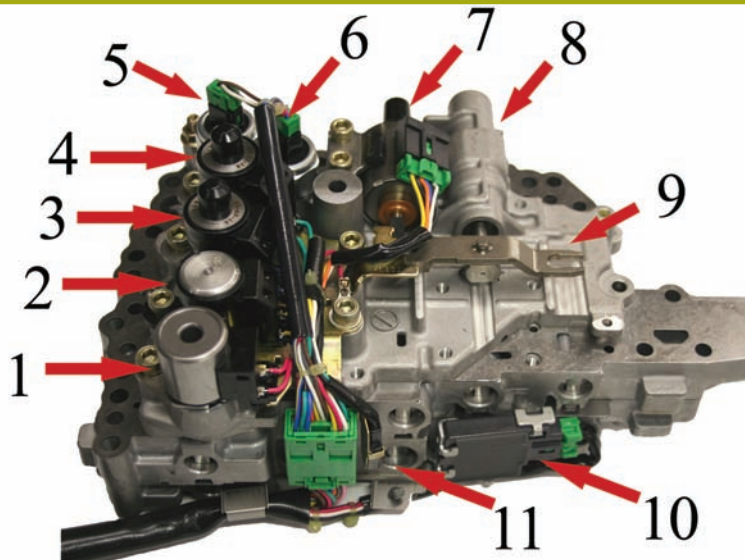

Figure 9

- | | |
|-------------------------------------|------------------------------------|
| 1 TCC Lockup/Select Switch Solenoid | 7 Stepper Motor |
| 2 TCC Control Solenoid | 8 Ratio Control Valve |
| 3 Secondary Pressure Solenoid | 9 Ratio Control Link |
| 4 Line Pressure Solenoid | 10 ROM |
| 5 Primary Pressure Sensor | 11 Transmission Temperature Sensor |
| 6 Secondary Pressure Sensor | |

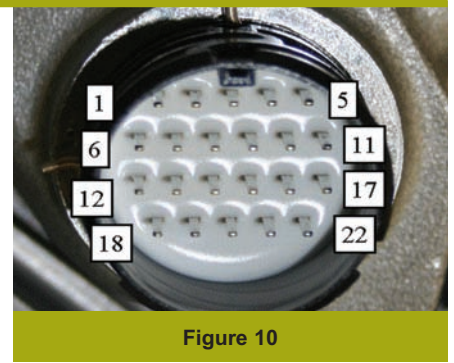

Figure 10

by the line pressure control solenoid, which is pulse width modulated (PWM) and high-side (B+) driven by the TCM. Line pressure is fed directly to the ratio control valve and the secondary valve to influence ratios and belt side loads (Figure 6).

The Valve body has a number of Screens and Valves (Figure 7 and 8).

The clutch reducing regulator valve lowers line pressure to 15 – 218 PSI to accommodate the forward and reverse clutches. These pistons only need enough pressure to apply adequate force on the clutch packs to prevent them from slipping.

When engaging drive or reverse, the TCC/clutch control PWM solenoid modulates to allow for smooth clutch apply. Once the vehicle is in gear, the select switch/TCC lockup solenoid allows the TCC/clutch control PWM solenoid to modulate the torque converter clutch apply and release.

The TCC/clutch control solenoid controls the apply pressure to the torque converter clutch. Once the TCC lockup control valve shuttles to the apply position, apply pressure regulated by the TCC/clutch control solenoid enters the torque converter. The regulated pressure allows for seamless application of the torque converter clutch. The pressures in the TCC apply circuit can vary between 0 to 145 PSI.

Unlike the Honda CVT, the JATCO CVT uses a torque converter. The purpose of the torque converter is to allow smooth acceleration from a standstill by providing a hydraulic disconnect from the engine. After rolling away from a stop sign, the torque converter clutch applies very early, usually at about 12 MPH.

Some of the advantages of a CVT include increased efficiency of power transfer and unlimited ratios, so the transmission control module (TCM) makes the most from the CVT by locking the converter as early as possible.

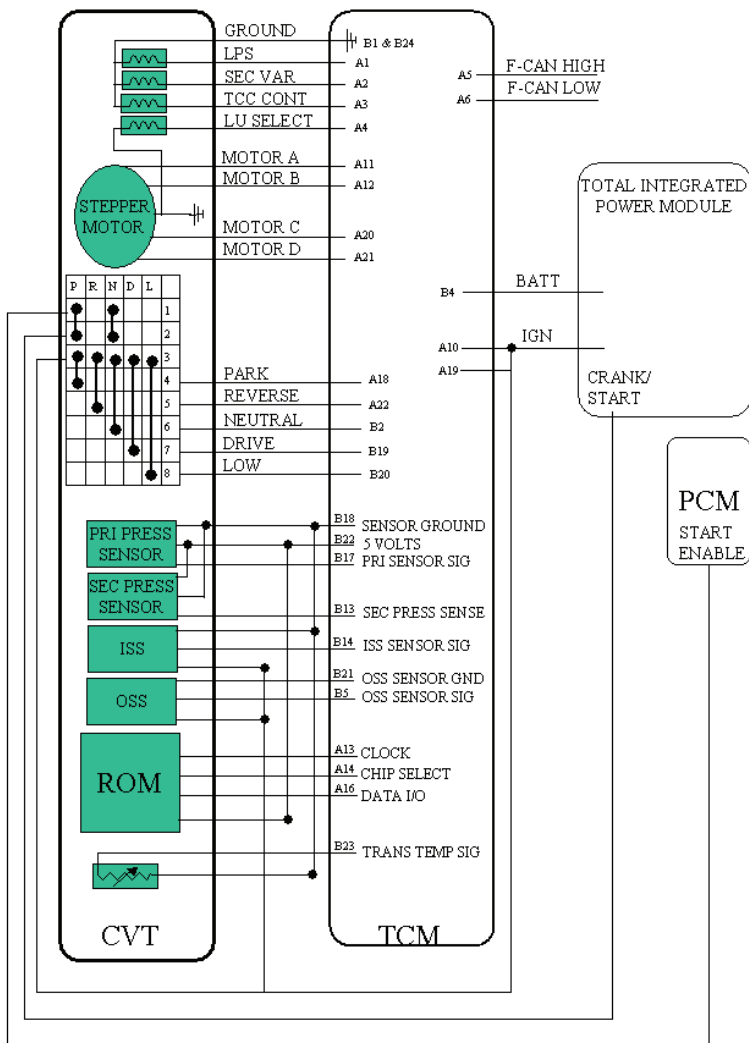

Figure 11

CASE CONNECTOR PINOUT AND REFERENCE VALUES

| Cav | Color | Function | Measurements |
|-----|-------|----------------------|------------------|
| 1 | DG/LB | Line Press Sol PWM | 3 – 9 ohms |
| 2 | YL/DB | Sec Press Sol PWM | 3 – 9 ohms |
| 3 | YL/LB | TCC Sol PWM | 3 – 9 ohms |
| 4 | YL/GY | TCC On/Off | 10 – 15 ohms (a) |
| 5 | PK/LB | 5-Volt Supply | 5 volts |
| 6 | BK | Ground | |
| 7 | PK/LB | Sec Press Signal | 0.7 – 3.5V (b) |
| 8 | LB/YL | Motor C | 10 – 20 ohms |
| 9 | YL/OR | Motor A | 10 – 20 ohms |
| 10 | YL/WT | Motor B | 10 – 20 ohms |
| 11 | TN/YL | Motor D | 10 – 20 ohms |
| 16 | YL/LB | Chip Select for ROM | |
| 17 | RD/WT | Trans Temp Signal | 5k ohms at 75°F |
| 18 | DG/YL | Primary Press Signal | 0.7 – 3.5V (b) |
| 19 | DG/VT | Sensor Ground | |
| 21 | DG/BR | Clock Select for ROM | |
| 22 | GY/YL | Data In/Out for ROM | |

(a) Observed 26.5 ohms on training center bench unit
 (b) Pressure transducers will output a varying voltage based on pressure. Monitor pressure with a scan tool then compare to actual pressure gauge readings. In neutral with the engine running, expect between 0.7 and 3.5 volts from the primary, and around 1 volt from the secondary.

Electronics

The CVT has three PWM solenoids: Line Pressure, Secondary Variator Pressure, and Torque Converter Clutch/Clutch Engagement. In addition to the PWM solenoids, the CVT has a single on/off solenoid for the TCC lockup/select switch valve (Figure 9).

The line pressure PWM solenoid controls the position of the line pressure regulator based on TCM decisions. The typical resistance of the line pressure solenoid is between 3 – 9 ohms. A vari-

ety of DTCs will set depending on a circuit or mechanical failure with the line pressure solenoid: DTCs P0746, P0962, P0963.

The Secondary Variator Pressure Control solenoid controls the position of the secondary variator pressure control valve. This valve regulates the release of fluid from the secondary variator during movement from high ratio to low ratio. Since the CVT relies on the secondary variator to provide the necessary clamping force on the belt, it's very important for this solenoid and valve assembly to work properly.

The following DTCs will set if there's a failure in the Secondary Variator circuit or valve: DTC P0776, P0777, P0966, and P0967. The TCM will look at the secondary variator pressure sensor to determine if the solenoid is operating properly. If the *actual* and *target* pressures don't match, a DTC will set.

While reviewing the wiring schematic, you might notice the ROM assembly. This is a chipset programmed when the transmission was assembled and carries vital information on the varia-

tors and hydraulic system. The ROM should never be interchanged with any other CVT. It is unique to the CVT it came with. In fact, if you exchange a CVT while reusing the original TCM, or swapping the original TCM with a used one, a "calibration mismatch" code P167A will set. In that case, you'll have to use a factory scan tool to go through a calibration procedure to recalibrate the TCM and ROM.

If you install a new TCM, a DTC P1679 "calibration not learned" will set, which will also require a recalibration using a scan tool. Regardless, it is important that the ROM assembly be kept with its original transmission.

The Transmission connector (Figure 10) has 22 pins but not all of the pins are used. These JATCO CVT equipped vehicles use the Controller Area Network (CAN) heavily for module-to-module communication (figure 11). The CAN is capable of sending up to 1 Mb/s of information across two wires, including vital sensor info such as TP, MAP, ECT, CKP, ect. When reviewing the TCM schematic, notice there are no dedicated circuits for engine speed, throttle position or load. The TCM relies on the CAN for these essential inputs.

Since the CVT is only available in new model vehicles that use the CAN bus, it's imperative that your scan tool be CAN capable. The DaimlerChrysler StarScan or StarMobile will undoubtedly have the most features available for diagnostics.

Here are diagnostic trouble codes related to the CVT:

| DTC | DESCRIPTION | NOTES |
|-------|---|--|
| P0219 | Engine Overspeed | Sets when CAN bus detects engine speed over 6800 RPM. |
| P0571 | Brake Switch | Sets if the brake switch status doesn't change but the computer registers MPH. This needs to fail in two consecutive key cycles to set a DTC. Beware two footed drivers. |
| P0602 | Control Module Programming Error/Not Programmed | TCM doesn't receive valid vehicle info from FCM. |
| P0610 | ECU Vehicle Options Mismatch | Probably set from using a different module for the TCM. FCM/TIPM |
| P0641 | Sensor Reference Voltage Circuit | Pressure sensors have less than 0.05V. Open or short to ground in sensor supply circuit. |
| P0707 | Transmission Range Sensor Circuit Low | Continuous loss of valid signal. Takes two failures to set a DTC. |
| P0708 | Transmission Range Sensor Circuit High | TCM receives more than two valid TR signals. |
| P0711 | Transmission Temp Sensor Performance | Trans temp doesn't change for 10 minutes or the calculated vs. actual temp varies by more than 104°F. |
| P0712 | Transmission Temp Sensor Low | Scan tool indicates 356°F. Short to ground, sensor failure, 68°F = 2.5k – 6.5k ohm, 176°F = 300 – 900 ohms. |
| P0713 | Transmission Temp Sensor High | Scan tool indicates -40°F. Short to power, open, sensor failure. |

Boost your rebuild

The new Sonnax Boost Valve Assembly for the Toyota U241E can save you **\$200** in valve body replacement costs.

COMPLAINT

SECONDARY COMPLAINTS

Insufficient line rise in drive ranges

• Higher-than-normal reverse pressures • Soft shifts

CAUSE

These problems can be caused by severe wear of the boost valve sleeve, allowing EPC and reverse oil leakage.

CORRECTION

The Sonnax boost valve assembly has upgraded materials and minimal clearances to prevent wear and restore proper hydraulic control.

Boost Valve Assembly

57917E-01K

1 Boost Valve
1 Boost Sleeve

Also Available

A130, A131, A140

89010-01K (Low Ratio)

89010-02K (High Ratio)

A540

89031-01K (High Ratio)

89031-02K (Low Ratio)

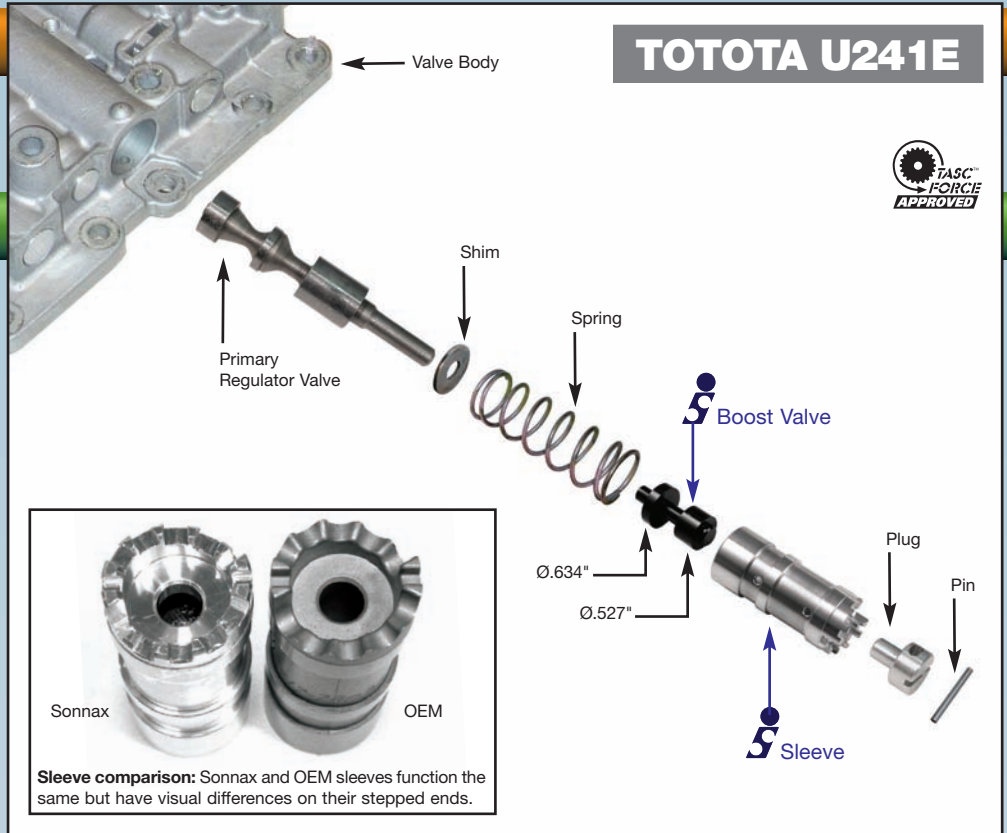

Sleeve comparison: Sonnax and OEM sleeves function the same but have visual differences on their stepped ends.

Toyota vehicles with a U241E transmission may exhibit insufficient line rise in the drive ranges and excessively high pressures in reverse. This can be caused by continuous oscillation of the steel boost valve within the cast-aluminum sleeve, creating excessive wear and a path for EPC and reverse pressures to leak. This leakage is further aggravated by the thermal expansion mismatch of the valve and sleeve materials. The Sonnax replacement boost valve assembly, **57917E-01K**, has upgraded and more closely matched materials, with minimal clearances to prevent wear and restore proper hydraulic control. The boost sleeve is manufactured from highly wear-resistant billet aluminum to prevent the excessive wear exhibited by the cast OEM sleeve, and the assembly restores proper line rise.



Automatic Drive P.O. Box 440
Bellows Falls, VT 05101-0440 USA
800-843-2600 • 802-463-9722 • F: 802-463-4059
www.sonnax.com • info@sonnax.com

See your nearest Transmission Specialties® distributor & ask for Sonnax® quality engineered products.



VISIT OUR WEBSITE FOR SONNAX® REAMERS & OTHER TOOLS

| DTC | DESCRIPTION | NOTES |
|-------|--|---|
| P0716 | ISS Circuit Performance | All must be met for this DTC: <ul style="list-style-type: none"> • CKP-Pri RPM > 1000 RPM • (Sec RPM x Est. Ratio) - Pri RPM > 1000 RPM • (CKP-Sec RPM) x Est. Ratio < 1000 RPM |
| P0717 | ISS Circuit No Signal | If OSS DTC sets there might be an issue with power. Both sensors are fed 12V from TIPM. Hall Effect: center terminal toggles 5V to ground. |
| P0721 | OSS Circuit Performance | All must be met for this DTC: <ul style="list-style-type: none"> • CKP-Pri RPM > 1000 RPM • (Sec RPM x Est. Ratio) - Pri RPM > 1000RPM • VSS - VSS Est. (using Sec RPM) ≥ 12.5 MPH |
| P0722 | OSS No Signal | If OSS DTC sets there might be an issue with power. Both sensors are fed 12V from TIPM. Hall Effect: center terminal toggles 5V to ground. |
| P0730 | Incorrect Gear Ratio | Sets when a difference between actual and target ratio exceeds 1000 RPM for 5 seconds. |
| P0741 | TCC Circuit Performance | Excess TCC slip detected for 30 seconds. Takes two failures to set a DTC. |
| P0746 | Line Pressure Solenoid Performance | A ratio of 2.7:1 detected for 0.2 second or 3.5:1 detected for 0.1 second. This would indicate a slipping belt. |
| P0776 | Secondary Pressure Solenoid Stuck Off (High Pressure) | Difference between actual and target pressure is over 174 PSI for 30 seconds. |
| P0777 | Secondary Pressure Solenoid Stuck On (Low Pressure) | If actual is lower than target by 36 PSI for at least 1.5 seconds twice within a 30 second window, or if actual is 291 PSI less than target for 800 ms. |
| P0826 | Up/Downshift Switch Circuit (Autostick Switches) | Sets when the upshift and downshift switches are closed at the same time or the switches are closed when the shifter isn't in drive. |
| P0842 | Primary Oil Pressure Circuit Low | Sets when voltage drops below 0.09V for 5 seconds. |
| P0843 | Primary Oil Pressure Circuit High | Sets when voltage rises above 4.7V for 5 seconds. |
| P0847 | Secondary Oil Pressure Sensor Low | Sets when voltage drops below 0.09V for 5 seconds. |
| P0848 | Secondary Oil Pressure Sensor High | Sets when voltage rises above 4.7V for 5 seconds. |
| P0962 | Pressure Control Solenoid A Circuit Low (Line Press Solenoid) | Check for short to ground and lack of power output from TCM. High side drivers in the TCM. |
| P0963 | Pressure Control Solenoid A Circuit High (Line Pressure Solenoid) | Check for opens and high resistance. TCM monitors current flow. |
| P0966 | Pressure Control Solenoid B Circuit Low (Secondary Pressure Solenoid) | Check for short to ground and lack of power output from TCM. High side drivers in the TCM. |
| P0967 | Pressure Control Solenoid B Circuit High (Secondary Pressure Solenoid) | Check for opens and high resistance. TCM monitors current flow. |
| P161B | Battery Disconnect/TCM Internal | Sets with a loss of power to the TCM. |
| P1661 | Sensor Ground Reference High | Check for opens or short to B+ on the sensor ground circuit. |
| P1679 | Calibration Not Learned | New TCM installed. |
| P167A | Calibration Mismatch | Swapping TCMs or Transmissions. |
| P1702 | Primary Oil Pressure Sensor/Secondary Oil Pressure Correlation | Comparison between valid signals between the two sensors. |
| P1723 | Lockup/Select Control Circuit | Invalid electrical voltages. |
| P1729 | Transmission Ratio Control Circuit (Stepper Motor) | Invalid electrical voltages. |
| P2769 | TCC Circuit Low | Check for short to ground and lack of power output from TCM. High side drivers in the TCM. |
| P2770 | TCC Circuit High | Check for opens and high resistance. |
| U0001 | CAN C Bus | Communication network problem. Might not get communication with scan tool if the problem is present. |
| U0100 | Lost Communication with PCM | Check connections and see if other modules can communicate. |
| U0121 | Lost Communication with ABS | Check connections and see if other modules can communicate. |
| U0141 | Lost Communication with IPM (FCM/TIPM) | Check connections and see if other modules can communicate. |

Although it may be a while before you see one of these CVTs in your shop, it's definitely time to get ready for this technology. CVTs could very well be the next trend for the automatic transmission industry. Six, seven, and

even eight speed transmissions are rolling off the assembly line every day, but they'll never achieve the infinite number of ratios found with a CVT.

With that said, there are a few things holding back a widespread CVT

market right now, including weight, torque capacity, and ratio-change speed. And at the rate technology is increasing, don't be surprised to see these issues addressed very soon.



It's a tough decision. Take your time.

Our Kits.

1. Better Parts



Nobody makes transmission parts more dependable. Freudenberg-NOK's Technology Center houses 70 engineering and materials professionals that have developed hundreds of patents and proprietary compounds

that improve gasket and seal performance. Our globally integrated supply of products from 85 automotive operations in 27 countries insures that we produce the best gaskets and seals.



2. More Parts.

We offer more parts and sell more parts than any other kit supplier. Every 12.7 seconds someone, somewhere, rebuilds a transmission with a TransTec® kit. That's 24 hours a day, 7 days a week, 365 days a year... and that doesn't even include our O.E. service kits.



3. History of Satisfied Customers

The companies that formed to bring you TransTec® kits have a long history of serving satisfied customers. In fact, we've been an O.E. supplier as long as there have been cars!



4. Lowest Overall Cost



Add it all up and you'll find TransTec® kits have the lowest overall cost. Better parts and better performance means less chance of a comeback. Get it all with TransTec® kits from Freudenberg-NOK, the O.E. supplier with aftermarket vision.

Their Kits.

1. Price

TRANStec®



T: 419.499.2502 • F: 419.499.3337
www.TransTec.com • Milan, OH 44846